

# Hot Foil Stamping Machine **STM-150-CS+**



# Hot Foil Stamping Machine

## STM-150-CS+



Heat transfer on round nail polish and lipstick containers



Customize (Decoration) Hot foil stamping on shampoo and conditioner bottle caps



Hot foil stamping on irregular shapes like oval, square and elliptical



Hot foil stamping on detergent bottle caps



Hot foil stamping on large compact base



Hot foil stamping on round large jar caps

### Options :

- Automatic part loading system
- Noise reduction enclosure for bowl feeder
- Counting and diverting arrangement - Reduce your dependence for 100% inspection
- End of foil roll - Bring down rejection and eliminate last piece inspection
- Cap elevator to feed caps on the bowl feeder - Ensure the machine doesn't starve for caps
- Heat transfer attachment - Cater to innovative market demand
- Remote diagnostic - For quicker and economical service support
- Conformity to CE norms

### Layout

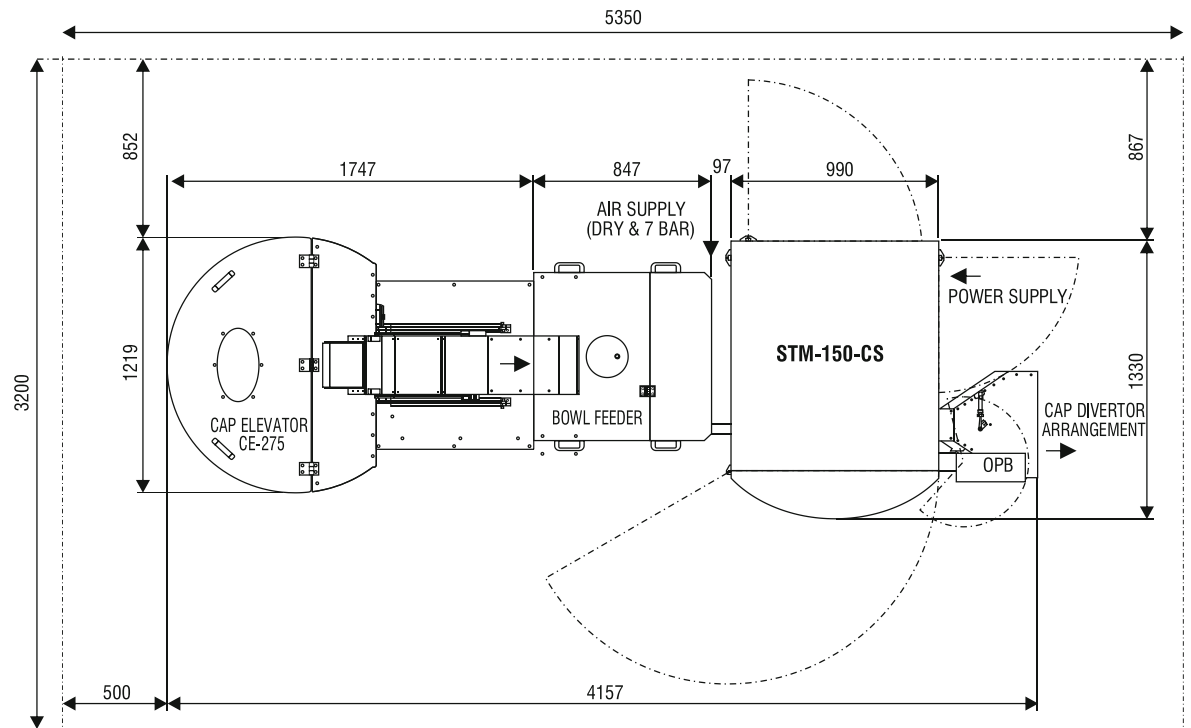

- Required Roof Height : 3 meters
- All Dimension are in mm